

Lesson 24: Maxwell's Theory of Electromagnetism

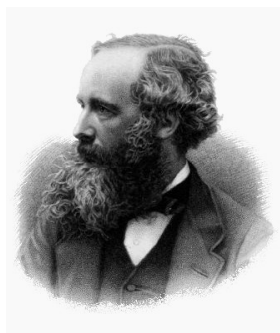

Illustration 1: James Clerk Maxwell

James Clerk Maxwell (first mentioned in Lesson 21) is one of the great tragedies of physics.

- Although he contributed a huge amount of work to physics, he died in 1879 at the age of 48.
 - Many scientists believe he was the most important physicist of the 19th century.
 - Some of his papers found at the time of his death were later interpreted to show that he was working on ideas that would have eventually led him to the Special Theory of Relativity, twenty years before Einstein!

Did YOU know?

Einstein had a picture of Maxwell hanging in his study.

Maxwell's greatest accomplishment was his **Theory of Electromagnetism**.

- Oersted had found that we can create a magnetic field by having current flow through a wire.
 - The strength of the magnetic field is predicted using **Ampere's Law** (Lesson 18).
- Moving a wire through a magnetic field induces a current to flow through the wire.
 - The amount of current induced is predicted using **Faraday's Law of Induction** (Lesson 20).
- Maxwell brought these ideas together while doing experiments with **capacitors**.
 - A capacitor is made up of two conductors that are not touching, each with the same amount of oppositely signed charge.
 - It was while using capacitors that he came up with an experiment that showed that a changing electric field resulted in a changing magnetic field which created a changing electric field which... you get the idea.

Maxwell made a series of predictions based on his research:

1. **EMR is produced whenever a charge accelerates.**

This is because the accelerating charge will produce a changing electric field, the start of the pattern of interrelated fields discussed already. It also means that the accelerating charge must be losing energy since it is emitting EMR (a form of energy).
2. **The frequency that a charge jiggles back and forth with will exactly match the frequency of the EMR produced.**

This makes sense, since the accelerating charge is what originally causes the fields that make up the EMR.
3. **All EMR travels at the speed of light, "c"**

Maxwell actually predicted a speed slightly higher than the current accepted value of 3.00×10^8 m/s, but give the guy a break! This was over 140 years ago! He also showed that we could use the universal wave equation $c = f\lambda$ for EMR.
4. **The electric and magnetic fields are perpendicular to each other, and perpendicular to the direction the wave is traveling.**

Picture the electric and magnetic fields as intertwined transverse waves. Since they create each other forever, we sometimes refer to EMR as a *self propagating wave*.
5. **EMR will do all the things any transverse wave should do.**

This includes ideas we will look at in later lessons like refraction, interference, and polarization.

Heinrich Hertz Helps!

In 1887 Heinrich Hertz performed an experiment to support the work Maxwell had done earlier. A simplified version of the experiment is explained here. *Note, although the fields actually surround this setup in 3D all the way around it, we will only look at what is happening to the right to keep it simple.*

- In *Illustration 2* we have just switched on an AC generator connected to two separate metal antennas.
 - Notice that with the current flowing down, the bottom antenna is negative and the top antenna is positive. This results in the **electric field** drawn in **red**.
 - Since this is basically acting like a regular current carrying wire, we can use the first hand rule to figure out the direction of the **magnetic field**, shown with the **blue X's**.

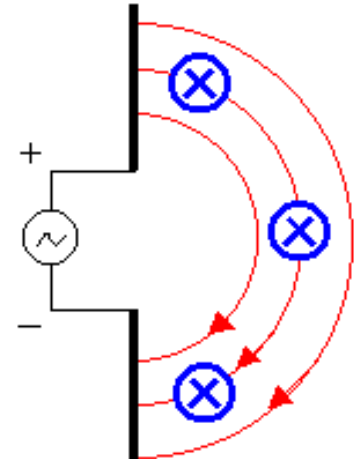
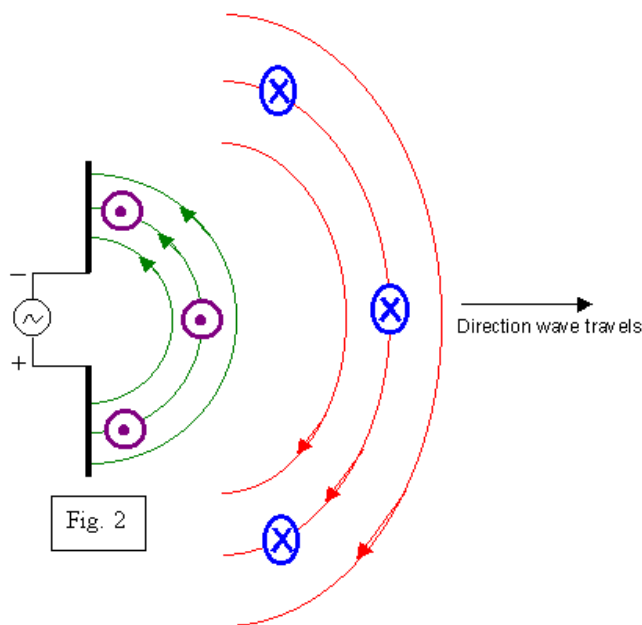

Illustration 2: The apparatus at the first moment that it was turned on.



A split second later, the AC generator being used has reversed the direction of the current (*Illustration 3*).

- See how the original **electric field** (in **red**) and original **magnetic field** (in **blue**) are still “feeding” each other as they expand outwards.
- Since the direction of the current has reversed, the new **electric field** (in **green**) is matched with a new **magnetic field** (in **purple**) that are pointing in exactly the opposite directions to the original ones.
- If we were to continue to watch this, we would see the electric fields created always go up or down, and the magnetic fields always go in or out.
- These are the intertwined transverse waves Maxwell predicted.

Illustration 3: The apparatus a split second later.

Using a setup similar to this Hertz was able to verify that the EMR was obeying the predictions Maxwell had made.

- Hertz used a metal ring as an antenna to detect the EMR being produced by his apparatus. This allowed him to verify that the frequency of EMR being produced matched the frequency being detected.
- He also set up a sheet of zinc to reflect the EMR and produce a standing wave. He was able to measure the wavelength this way, and along with the frequency and the universal wave equation, showed that the EMR was traveling at 3.00×10^8 m/s.

Homework

p647 #4, 5, 7, 8, 11, 12, 14